

Blinddose:
Dummy Receptacle:
B39-381- _ _

Passend für freie Steckverbinder nach Serien:
To suit plug connectors to series:
MIL-DTL-38999 Series III; JN1034; CECC75-201-002;
EN3645-001; BS9520 G0003; VG95319-100x

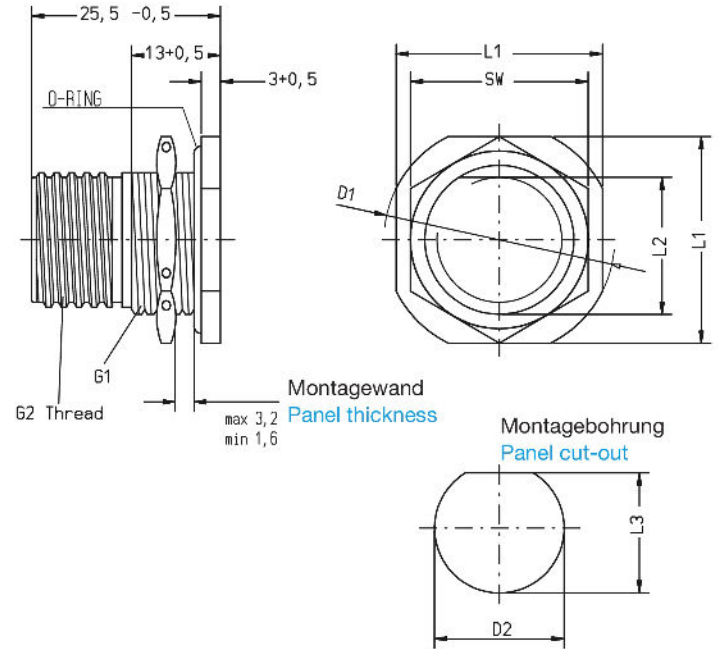

Die Maße der Sechskantmutter entsprechen der VG 95319-1010 Spezifikation.

The dimensions of the panel nut are as required by the VG 95319-1010 Specification.

Größe: Shell Size:	EMCA Teile-Nr. Part No.	L1 ±0,3	L2 0 -0,25	L3 0 -0,25	G1 Gewinde Thread Size	G2 Thread Size Class 2A 0.1P-0.3L-TS	D1 max	D2 +0,25 0	Anzugsdrehmoment Torque Nm	SW 0 -0,1
9	B39-381-0x1	26,97	16,3	16,99	M17x1	0.6250	30,45	17,70	10	22
11	B39-381-0x2	31,75	18,8	19,53	M20x1	0.7500	35,20	20,88	16	27
13	B39-381-0x3	34,93	23,7	24,26	M25x1	0.8750	38,38	25,58	20	30
15	B39-381-0x4	38,10	26,8	27,53	M28x1	1.0000	41,55	28,80	20	34
17	B39-381-0x5	41,28	30,2	30,68	M32x1	1.1875	44,37	31,98	30	36
19	B39-381-0x6	46,02	33,5	33,86	M35x1	1.2500	49,50	35,15	30	41
21	B39-381-0x7	49,23	36,6	37,06	M38x1	1.3750	52,65	38,28	30	46
23	B39-381-0x8	52,37	39,7	40,01	M41x1	1.5000	55,85	41,50	40	46
25	B39-381-0x9	55,58	42,8	43,41	M44x1	1.6250	59,00	44,68	40	50

Maße in mm/Dimensions in mm

X in EMCA Teile-Nr. X in Part No.	Basismaterial Base Material	Oberflächenbehandlung Plating finish
B39-381-*5*	Aluminium Legierung Aluminum alloy	Stromlos vernickelt Electroless nickel
B39-381-*6*	Aluminium Legierung Aluminum alloy	Cd grün chromatiert Cadmium olive drab
B39-381-*9*	Marine Bronze Marine Bronze	-
B39-381-*1*	Edelstahl-nichtrostend Stainless Steel	Passiviert Passivated

Weitere Oberflächen auf Anfrage.

Please contact the factory for other available plating finishes.